

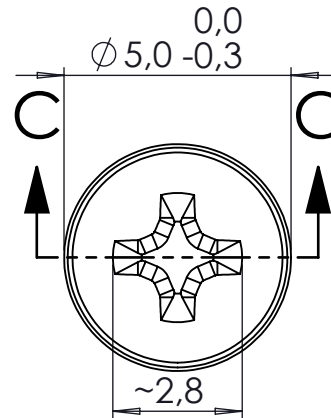

KESIT C-C



PH1

REV. NO	DATE	REVISED BY	DESCRIPTION OF CHANGE
			www.altinkaya.com
Customer Name:		Customer Ref.:	
Altinkaya Ref.: VD-325-10-0-M-D / VD-325-10-0-S-D		Part Name : M2,5 Pan Head Metric Screw - Zinc	
DRAWN	NAME	DATE	Drawn From:
CHECKED	Y.YEL	26.02.2025	Material : Metallic A2F Cr+3 / Black A2S Cr+3 over 20Mn-B4
DIMENSIONAL TOLERANCES UNLESS OTHERWISE SPECIFIED (DIN7168)		0.5-3mm	3-6mm
		6-30mm	30-120mm
		120-400mm	Dimension (mm)
		±0,1	±0,1
		±0,2	±0,3
		±0,3	±0,5
		±0,5	m (medium)
		SCALE:6:1	SHEET 1 OF 1

A4

