

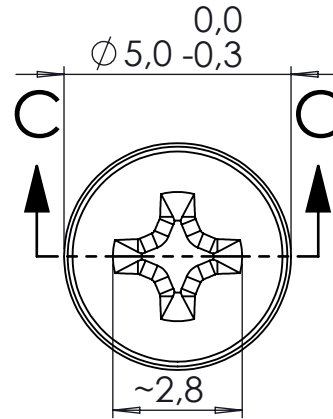

2.5x0.45 mm 6h
Thread

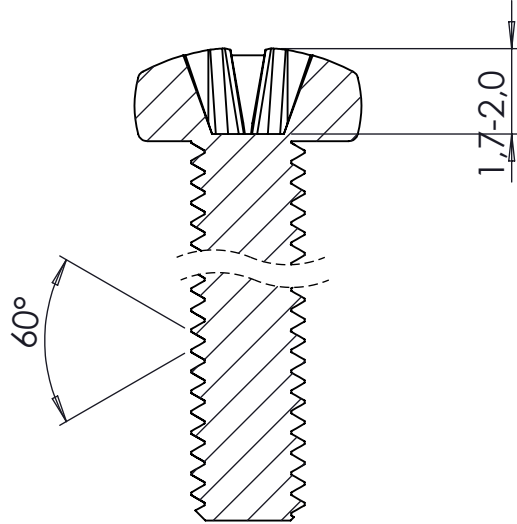
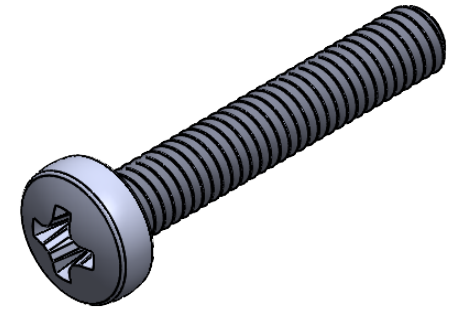
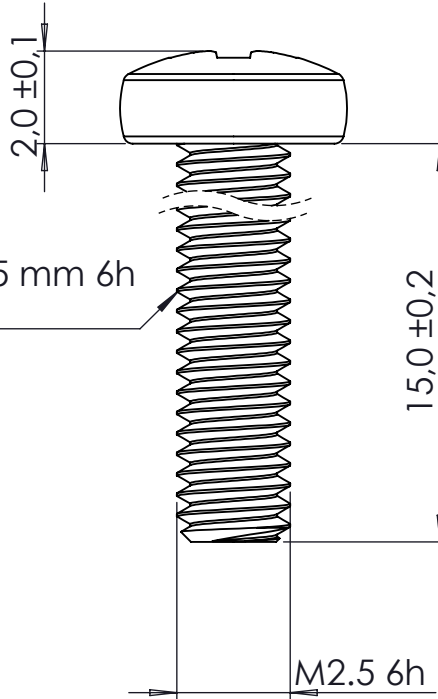

REV. NO	DATE	REVISED BY	DESCRIPTION OF CHANGE				
			www.altinkaya.com				
Customer Name:		Customer Ref.:					
Altinkaya Ref.: VD-325-15-0-M-D / VD-325-15-0-S-D		Part Name : M2,5 Pan Head Metric Screw - Zinc					
DRAWN	NAME	DATE	Drawn From:				
CHECKED	Y.YEL	26.02.2025	Material : Metallic A2F Cr+3 / Black A2S Cr+3 over 20Mn-B4				
DIMENSIONAL TOLERANCES UNLESS OTHERWISE SPECIFIED (DIN7168)		0,5-3mm	3-6mm	6-30mm	30-120mm	120-400mm	UNIT : mm
		±0,1	±0,1	±0,2	±0,3	±0,5	m (medium)
SCALE:6:1						SHEET 1 OF 1	

A4

