

KESIT B-B

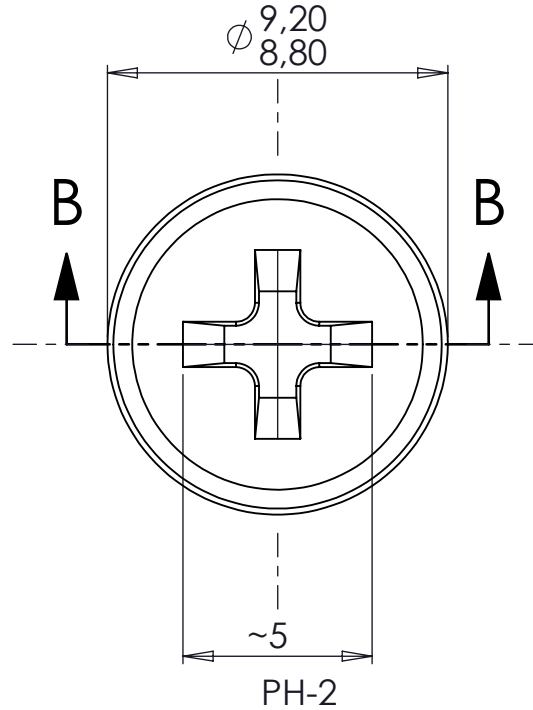

REV. NO	DATE	REVISED BY	DESCRIPTION OF CHANGE				
		www.altinkaya.com					
Customer Name:		Customer Ref.:					
Altinkaya Ref.: PS-501-08-0-N-0		Part Name : M5 Plastic Screw					
DRAWN		NAME	DATE	Drawn From:			
CHECKED		Y.YEL	2.12.2024	Material : PA6 %30GF			
DIMENSIONAL TOLERANCES UNLESS OTHERWISE SPECIFIED (DIN7168)		0,5-3mm	3-6mm	6-30mm	30-120mm	120-400mm	UNIT : mm
		±0,1	±0,1	±0,2	±0,3	±0,5	m (medium)
SCALE:5:1						SHEET 1 OF 1	A4