

SECTION A-A
SCALE 1 : 2

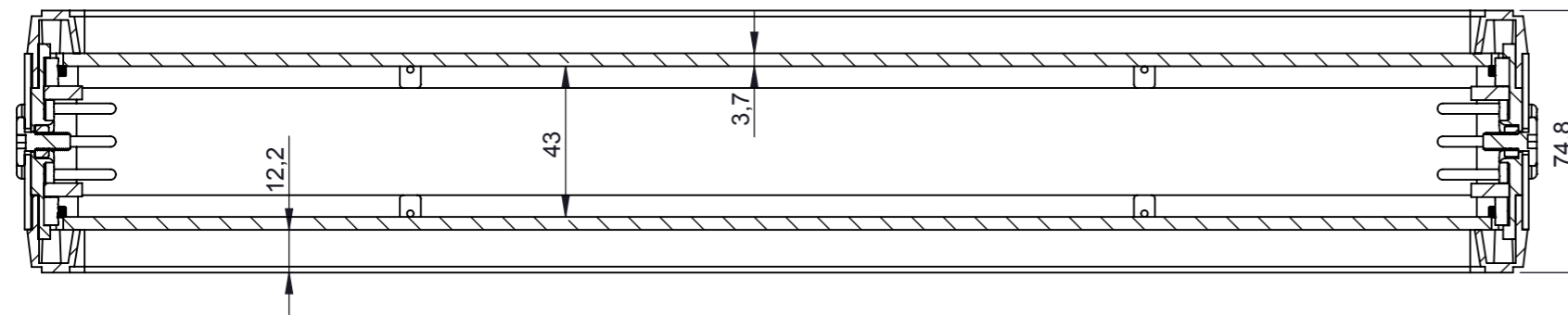

SECTION B-B

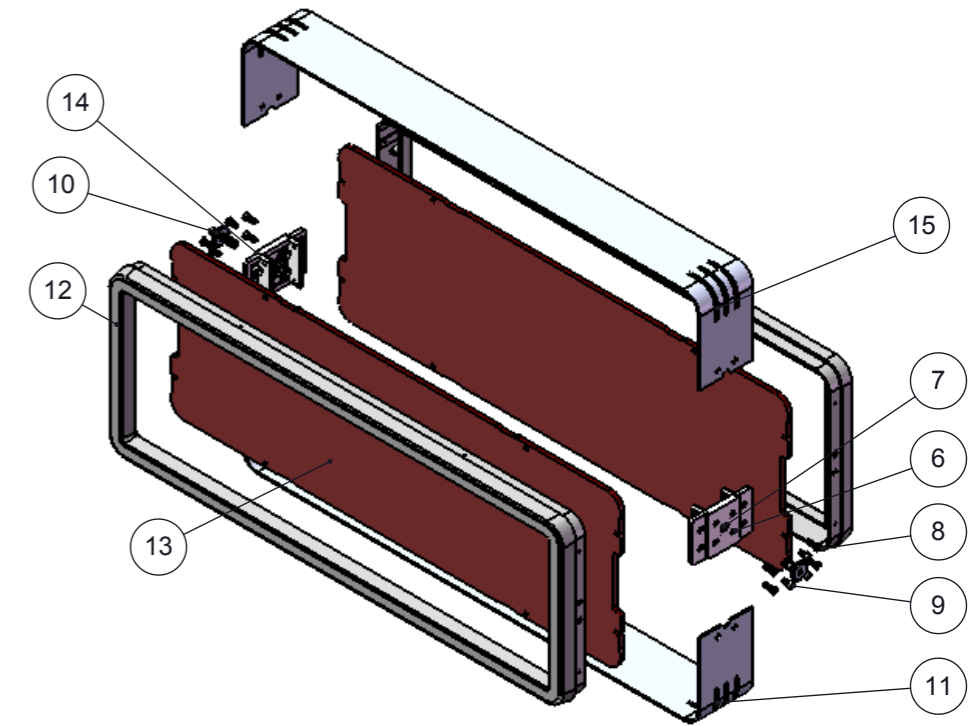

ITEM NO.	PART NUMBER	DESCRIPTION	QTY.
11	DE-150-P-1-10456-	sac kapak	1
12	DE-140-P-2-10402	cerceve	2
13	DE-140-P-3-10403	panel	2
14	DE-150-P-2-11198	ic yan destek	2
15	DE-150-P-1-10456	sac kapak	1
6	A-606-0-0-M-0-10327	M3x0,5x2,2 mm Metallic Nut	16
7	M5_nut	M5x0,8x4 mm Metallic Nut	2
8	A-603-0-0-M-0-10325	M3 X 8 mm YSB Metallic Screw	8
9	A-622-0-0-M-0-10400	M3x6 mm YSB Metallic Screw	8
10	A-60-0-0-M-0-10326	M5 x 13 mm Bighead Metallic Screw	2

<small>PROPRIETARY AND CONFIDENTIAL THE INFORMATION CONTAINED IN THIS DRAWING IS THE SOLE PROPERTY OF ALTINKAYA ENCLOSURES. ANY REPRODUCTION IN PART OR AS A WHOLE WITHOUT THE WRITTEN PERMISSION OF ALTINKAYA ENCLOSURES IS PROHIBITED.</small>		ARTICLE NO:	REVISION:
<small>DRAWN Dursun Daşdemir 02.06.08 CHECKED Ali Altıngök 02.06.08 COMMENTS:</small>		 ALTINKAYA ENCLOSURES FOR ELECTRONICS	CONTACT: www.altinkaya.com.tr
MATERIAL:		TITLE: DE-150 gösterge kutusu	
WEIGHT:		DWG NO. DE-150-B-B-10455	A3
SCALE:1:2		SHEET 1 OF 1	